

ANTARES

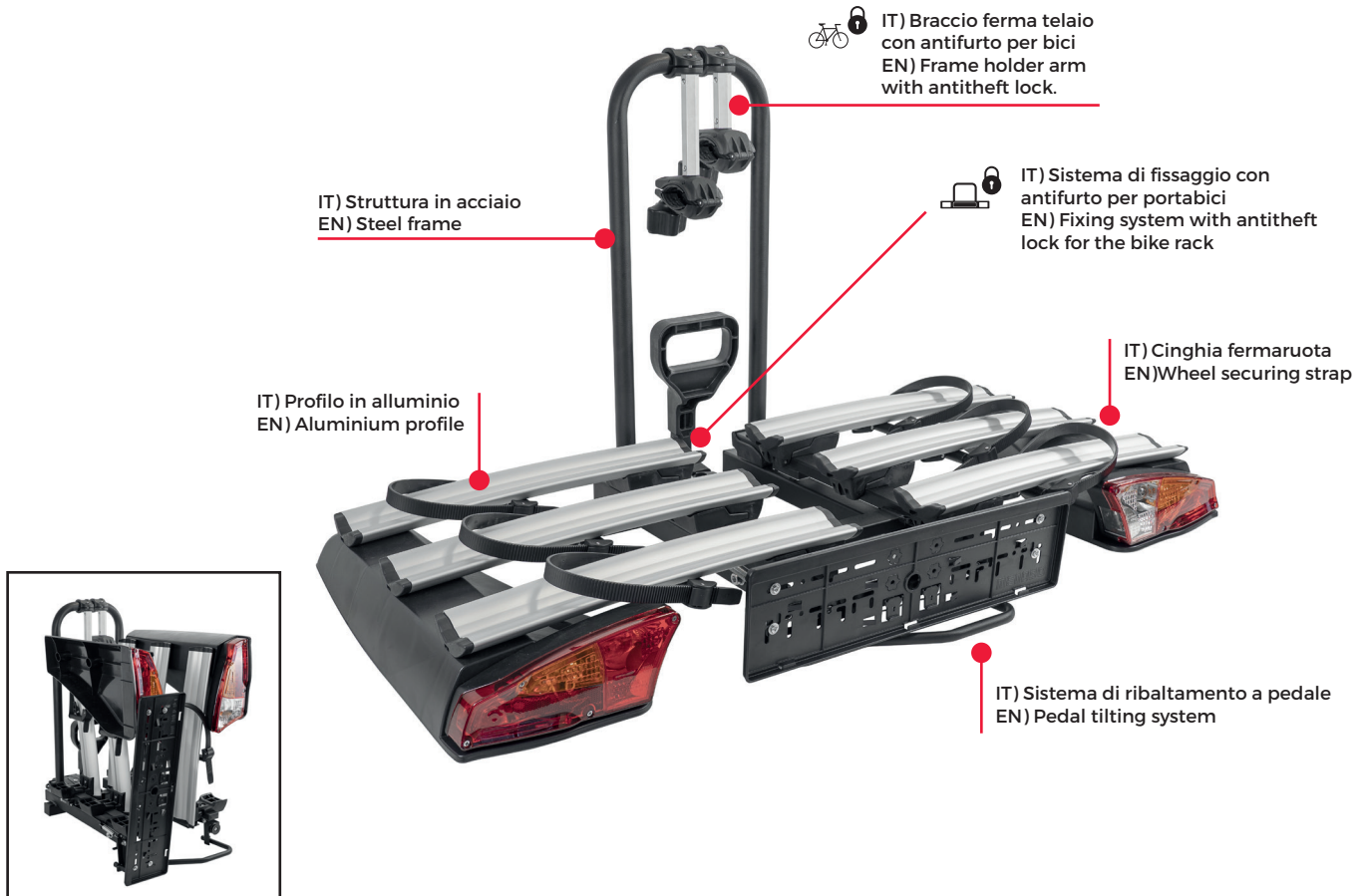

ANTARES



ANTARES 3



TILTING SYSTEM



RAPID LOCK



LOCK



13 PIN

IT) Portabici da gancio richiudibile con sistema di aggancio rapido, telaio in acciaio ad alta resistenza e profili in alluminio. Dotato di sistema di ribaltamento a pedale e di doppio antifurto.

EN) Foldable towbar bike rack with quick lock system, sturdy steel frame and large aluminium wheel rails. Antares is equipped with a pedal tilting system and double antitheft system.



Antares 2
Art. 000126300000



Antares 3
Art. 000103400000



Watch video

ANTARES 2 / ANTARES 3

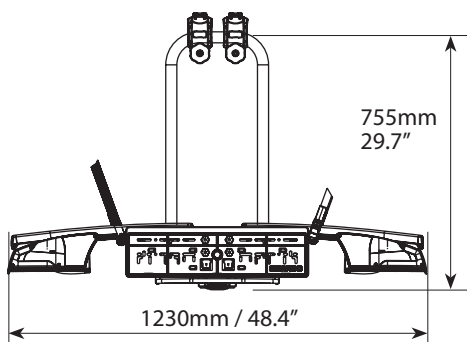

ANTARES 2 / ANTARES 3

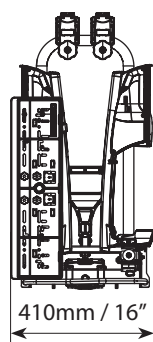

ANTARES 2

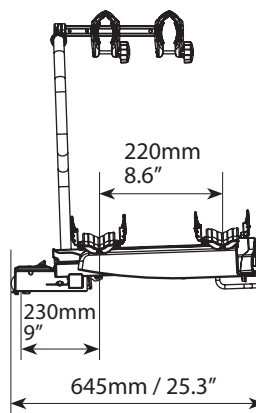

ANTARES 3

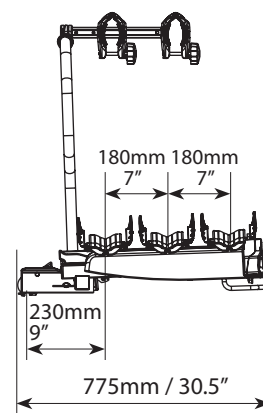

Art.	Antares 2	000126300000
	Antares 3	000103400000
	Antares 2	16kg/35.2lb
	Antares 3	18,4kg/40.5lb
Materiale Material Matière	Alluminio e acciaio Aluminium and steel Aluminium und Stahl Aluminio y acero Aluminium et acier	
	Antares 2	max 60kg / 132lb
	Antares 3	max 60kg / 132lb
	✓	
	✓	
Max	Antares 2	2
	Antares 3	3
Fat bike	✓	
E-bike	✓	

Mod.	ANTARES 2	ANTARES 3
Art.N°	000126300000	001034000000
	L x W x H : 42x65x77 cm / 16.5x25.5x30.3"	L x W x H : 42x78x77 cm / 16.5x30.7x30.3"
	19 Kg / 42lb	22 Kg / 48.5lb
	L x W x H : 130x84x211 cm / 51.2x33x83"	L x W x H : 126x80x211 cm / 49.6x31.5x83"
	211 Kg / 465.2lb	175 Kg / 386lb
	Pz: 10	Pz: 7
Ean-13	8 003168 047803	8 003168 035497

**COMPATIBILITÀ BICI
BIKE COMPATIBILITY
VÉLOS COMPATIBLES
BICICLETAS COMPATIBLES
PASSENDE FAHRRÄDER**

Mod.					
ANTARES 2 / ANTARES 3	 min: 30mm/1.2" max: 50mm/2.3"	 min: 30x60mm/1.2x2.3" max: 50x70mm/2x2.7"	 min 22" max 29"	 max 110mm/4.3"	 max 1130mm/44.4"

F.lli Menabò s.r.l.

Via 8 Marzo 3,
42025 Cavriago (RE), Italy
customer@flli-menabo.it
www.menabocaraccessories.com